

Transfer units and angular gears

Application examples

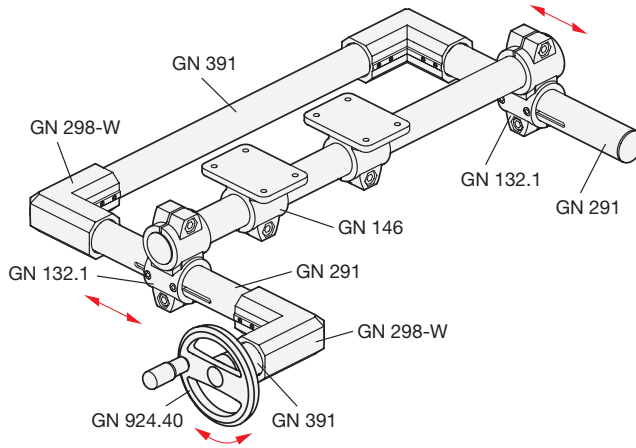

Two parallel sliding linear actuators GN 291 are connected with a transfer unit GN 391.

The angular housings GN 298-W including the bevel gear wheels GN 297 and another transfer unit GN 391 connect the handwheel with the system. The handwheel is placed in a rectangular position to the moving axes.

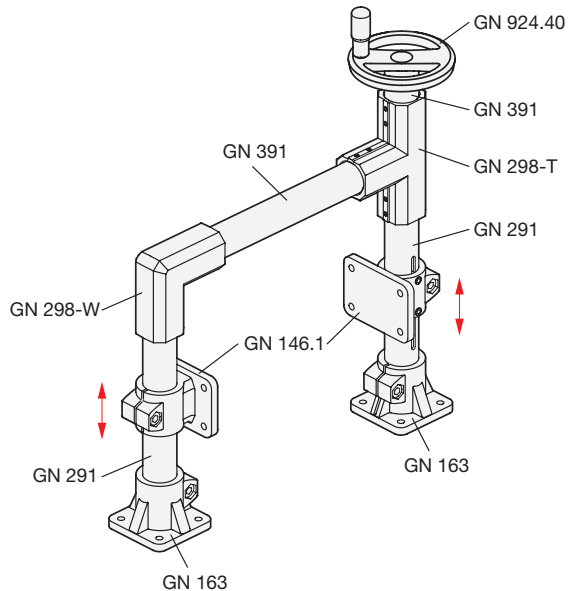

Two flanged linear actuator connectors GN 146.1 are moved parallel. For this two linear actuators GN 291 are connected with a transfer unit GN 391.

The T- and angular gear GN 298-T/W including the bevel gear wheels GN 297 and another transfer unit GN 391 connect the handwheel with the system. The handwheel is placed in a parallel position to the moving axes.