

Function

Fixed firmly to the housing or the operating element, the pointer shaft with the longer red pointer is mounted at the centre of the position indicator. The red pointer therefore shows the revolution of the spindle at a ratio of 1 to 1, at the same time turning in the same direction as the spindle. The pendulum is positioned freely on the same pointer shaft, with the pendulum not turning in sync but always held in the same position owing to its force of gravity.

The scale and the gear wheels required for the desired reduction ratio of the second pointer are mounted on this pendulum. The rotary motion of the operating element is now transferred to the second, shorter pointer via a gear wheel fixed to the pointer shaft and via the reduction gearing at the fixed pendulum. Any position (rotary position) of the spindle can now be read with accuracy on the scale.

Use

The outstanding feature of pendulum-type position indicators is that the measuring system is fully integrated in the operating element. During installation, they require no further measures on the machine side.

In principle, these position indicators have been designed solely for attachment to horizontal spindles, but the high precision of the mechanical measurement system (the pendulum system is mounted on ball bearings) and the extremely low centre of gravity allow these to be used also for spindles inclined by as much as 60°.

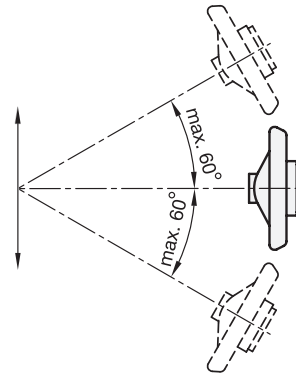

Selecting the reduction

While the longer red pointer shows the rotary motion of the spindle of a ratio of 1 to 1, the shorter black pointer makes only a fraction of the rotary motion defined by the reduction ratio.

The reduction ratio is selected depending on the maximum number of spindle revolutions over the entire range of adjustment. The preferred selection is the standard reduction ratio which is the same as or, if possible, slightly larger than the maximum number of revolutions.

Example:

Spindle adjustment range: 11 revolutions

Selected reduction ratio: 12 to 1

This selection gives virtually the whole scale range for the position indication.

Scale

The standard scales have divisions (number of graduation marks) matching the reduction ratio.

The numerical sequence also matches the reduction ratio depending on use, i.e. right turn (clockwise) or left turn (anticlockwise).

If required and using a separately arranged table, the measured value corresponding the application in hand can be assigned to each scale number.

Special scales on request.

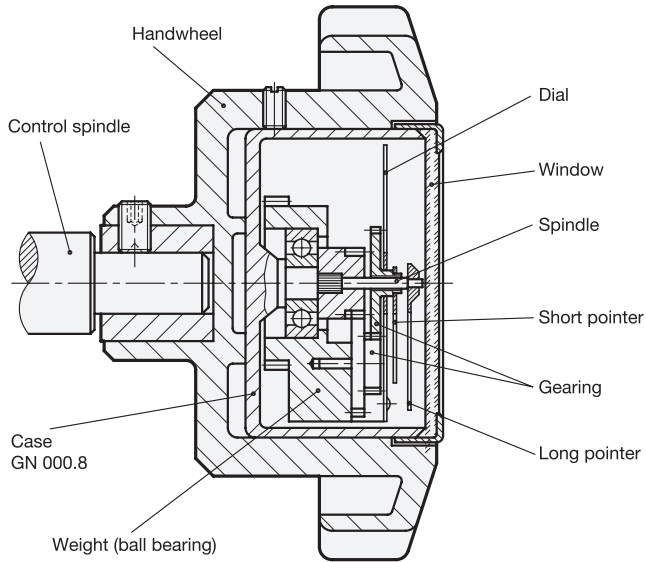

Examples of 12:1 standard dial

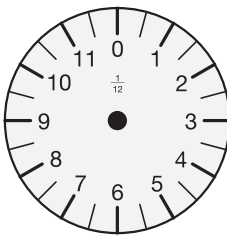

Figures rising by clockwise rotation

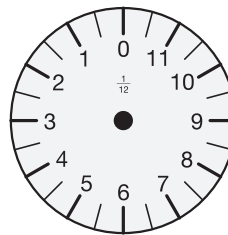

Figures rising by anti-clockwise rotation